



Project:	
Location:	
Model#: SLSQ63K-UNV-BZ	Type:
Client:	Qty:
Prepared by:	Date:

SERIES SPECIFICATIONS



To supply TamLite's SLSQ Series of LED Square Step Light Luminaire as specified. The luminaire shall operate at 120-277Vac. The housing shall be constructed of powder coated diecast Aluminium with impact resistant polycarbonate lens. The LEDs shall be as specified LUMILEDS® LUXEON 3030 2D LED chips. The luminaire shall be cULus Listed.



PERFORMANCE SPECIFICATIONS

Luminance Distribution Chart

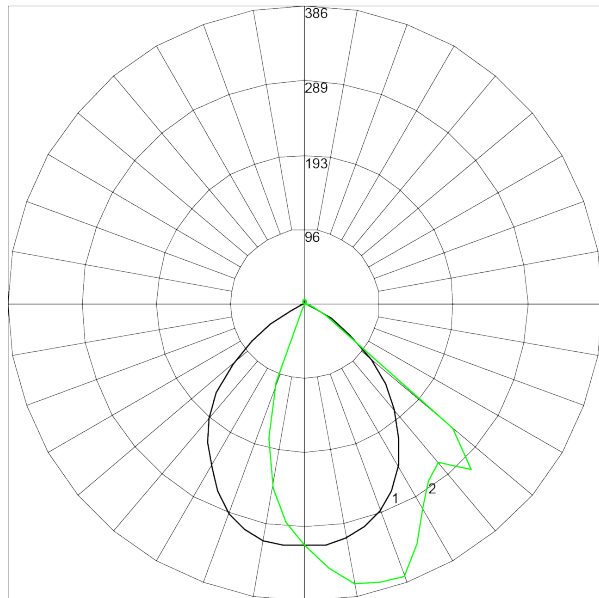

Maximum Candela = 385.54 Located At Horizontal Angle = 112.5, Vertical Angle = 20
 # 1 - Vertical Plane Through Horizontal Angles (0 - 180)
 # 2 - Vertical Plane Through Horizontal Angles (90 - 270)

Isolux Diagram

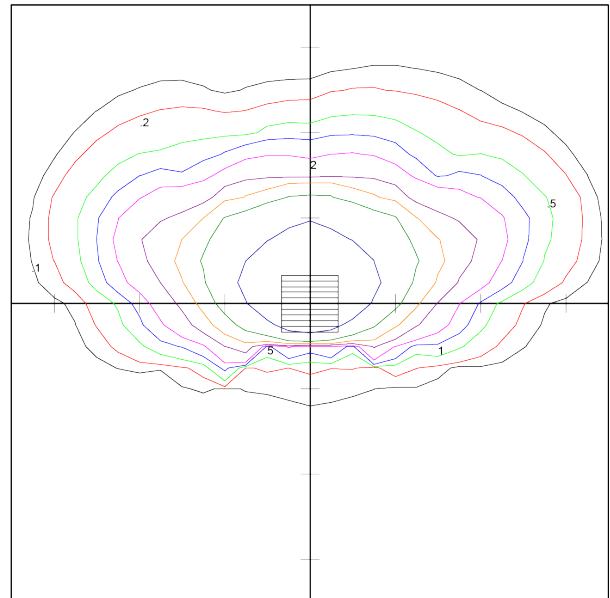

TAMLITE LIGHTING
 CALEDON, ONTARIO
 SLSQ63K-UNV
 TAMLITE 6W SQUARE STEP LIGHT

Horizontal Footcandles
 Scale: 1 Inch = 1.5 Ft.
 Light Loss Factor = 1.00
 Lumens Per Lamp = 559.1
 Total Lamp Lumens = 559.1
 Mounting Height = 1.50 Ft
 Maximum Calculated Value = 151.77 Fc
 Arrangement: Single

Project:	
Location:	
Model#: SLSQ63K-UNV-BZ	Type:
Client:	Qty:
Prepared by:	Date:

Zonal Lumen Summary

ZONE	LUMENS	ZONE	LUMENS	ZONE	LUMENS	ZONE	LUMENS	ZONE	LUMENS
0-10	29.8	40-50	110.51	80-90	1.2	120-130	2.04	160-170	1.24
10-20	82.05	50-60	75.32	90-100	1.25	130-140	2.19	170-180	0.44
20-30	105.5	60-70	27.34	100-110	1.5	140-150	2.15	--	--
30-40	108.68	70-80	4.26	110-120	1.78	150-160	1.85	--	--

Initial Lumen Output: 555lm

Spacing Criteria: 1.15 (C0/180), 0.85 (C90/270)

Ambient Operating Temp: -20C to +40C

Limited Product Warranty: 5 Year(s)

Efficacy: 81.19lm/W

Environmental Rating(s): IP65

Certification Standards: UL Safety US-CA

BUG Rating: B0-U2-G0

UL Classification: Wet Location Listed

CCN Number: IFAM7.E359675

LED SPECIFICATIONS

SPD

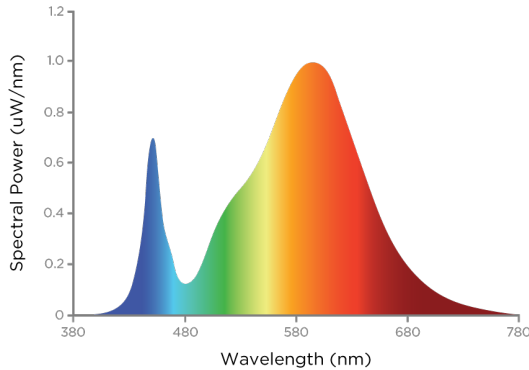

Source Type: LED

CRI: >70

Chromaticity: x=0.43693 y=0.40407

Manufacturer: Lumileds®

L70: 36000 Hrs.

Colour Tolerance: 5 SDCM

Part Number: LUXEON 3030 2D

Colour Temperature: 3000K

Duv: 0.0005



Project:	
Location:	
Model#: SLSQ63K-UNV-BZ	Type:
Client:	Qty:
Prepared by:	Date:

ELECTRICAL SPECIFICATIONS

Input Voltage: 120-277Vac

Auxiliary Control:

Dimming Current mA:

Driver Certifications: c-RU-us Class 2,
FCC Part 15 Class B, RoHS

Input Frequency: 50/60 hz

Power Factor at 120Vac: > 0.90

Over Temperature Protection: Auto
Recovery. Returning to normal after over
temperature is removed.

Fixture Draw: 6.89W

Dimming: 0-10Vdc, (0% Min Light Level)

Short Circuit Protection: Auto Recovery.
The output shall return to normal when the
fault condition is removed.

PHYSICAL SPECIFICATIONS

Finish Colour: Bronze (RAL-8019)

Housing Material: ADC12 Aluminium

Finish Type: Textured powder coat over
chromate conversion coat

Lens Material: PMMA

Mounting: Wall Mount

Lens Type: Clear

SHIPPING INFORMATION

OrderingCode(s): SLSQ63K-UNV-BZ

Carton Quantity: 24

Box Quantity: 1

Carton Dimensions (L-W-H): 435 x 400 x
310 mm

Box Dimensions (L-W-H): 141 x 96 x 145
mm

Project:	
Location:	
Model#: SLSQ63K-UNV-BZ	Type:
Client:	Qty:
Prepared by:	Date:

LINE DRAWING

Line Drawings

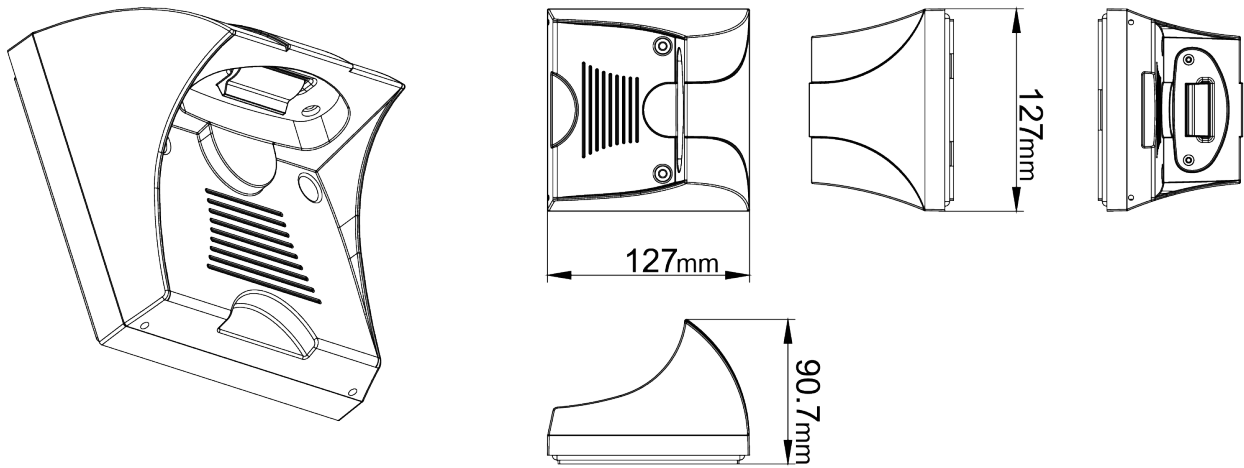

SERIES ARCHITECTURE

Series Architecture

SLS Nomenclature

Part	Watts	CCT	Mounting	Voltage	Finish
SLSQ	6 6W	3K 3000K	Blank Surface	UNV 120-277VAC	BZ Bronze
SLSR		5K 5000K			BK Black
					WH White
					CC Custom